

# Marlin Owners Club

SEPT 87

## PIT-STOP

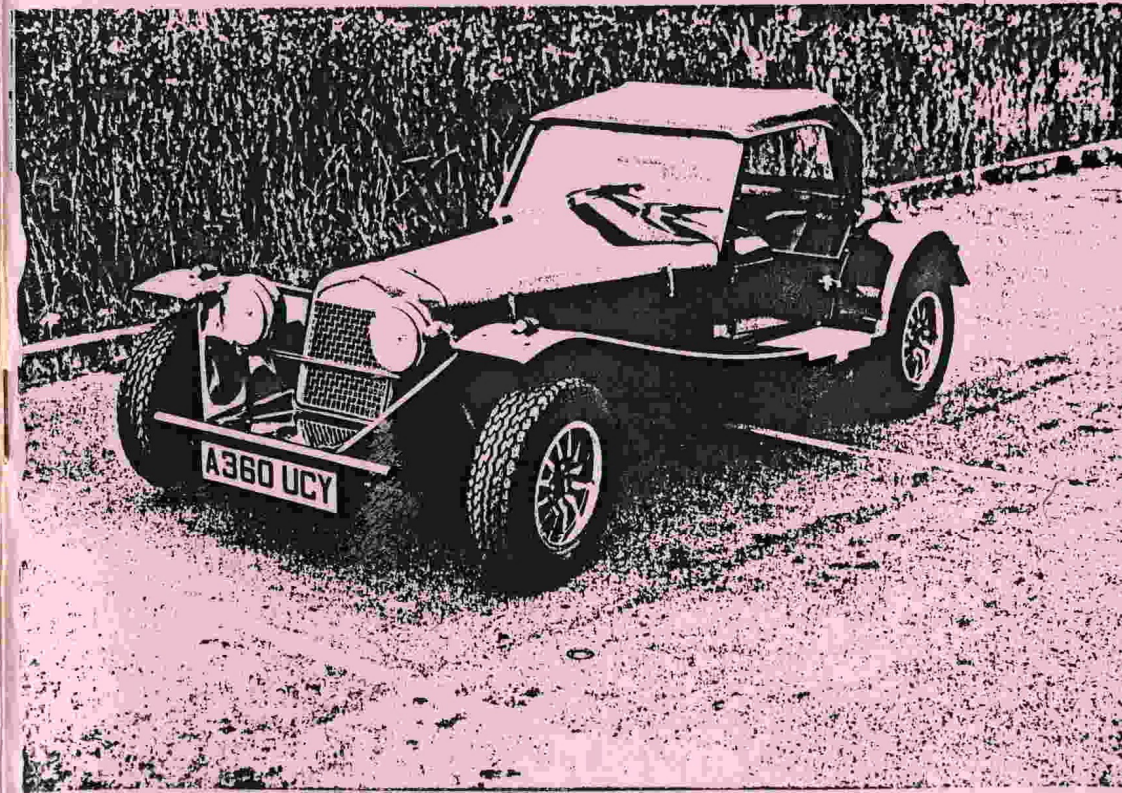
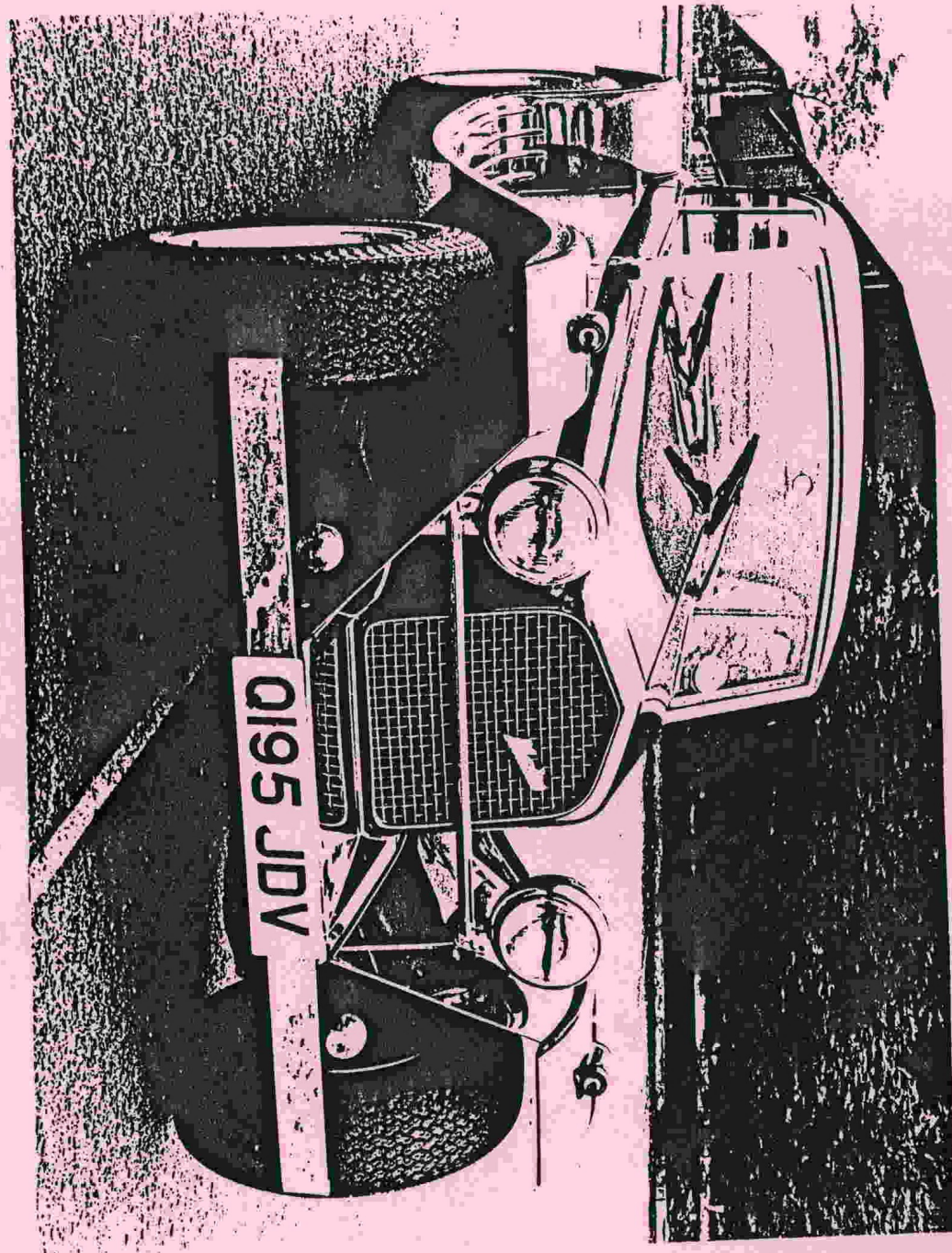

Hon. President

Paul Moorhouse c/o Marlin Engineering

Chairman & Events Organiser

Margaret Priest,  
4 Springbank Lane, Bamford, Rochdale, Lancs.  
Tel: 0706 357 046

Secretary Membership & Editorial

Val Hoyle,  
1 Woodthorpe Drive, Cheadle Hulme, Ches.  
Tel: 061 485 7444

Treasurer

Andrew Priest,  
4 Springbank Lane, Bamford, Rochdale, Lancs.  
Tel: 0706 357 046

Technical Advisers

Berlinetta:	Phil Robertson	- 044 634 551	S.Glam.
	Chick Ewen	- 066 461 669	Leics.
	Don Collins	- 0452 410 412	Glouc.
Marina:	Graham Hoyle	- 061 485 7444	Ches.
	Jim Davis	- 0734 751 691	Berks.
Triumph:	Andrew Priest	- 0706 357 046	Lancs.
Trim:	Peter Hare	- 093 633 749	Staffs.
	Chris Rushforth	- 0926 314 666	Warks.
Construction & Regulatory Matters:	Jim Reilly	- 021 350 1461	W.Mids.

MADAM CHAIRMANS PAGE

The show season is nearly over and apart from Capesthorpe we have all managed to keep dry. There must even have been some burnt faces driving back from Fleetwood. I was certainly well cooked without being in a Marlin. The standard of the cars this year has been unbelievable with prizes and highly commendeds being won at all the major shows. Congratulations for keeping the flag flying to Peter Hare, for a second year running, Chris Rushforth, Nigel Ellis and a late entrant Terry Hambley.

The Club has been well represented at all the shows, thanks to you all for turning up.

Unfortunately I couldn't make Harewood again this year but I promise to turn up in 1988 and would ask Bryan to reserve me an entry pass.

I can't make the French Trip but hope that all involved have a super time and I look forward to reading the articles and seeing the pictures. A word of warning though, don't follow Val. It took her hours to find Fleetwood and did you see her 'guiding' Graham round the Autotest at Sandown?

For the record (and those that are interested), two of our very early members have got married this year - Peter House (the driving skills expert) and Charles Lancaster (our ex Chairman). Congratulations to them and the other half dozen who tied the knot or are about to in 1987.

Margaret

DIARY DATES

August	29	Harewood Steam Fair (Yorks.K.C.C.)
August	29/30/31	North Classic Car Show, G-Mex Centre, Manchester (indoor event).
September	19	Kit Cars & Specials Day, Castlecombe.
October	4-9	Club Trip to France, 1987. Portsmouth to Caen, then based at Le Mans, with tours of the Loire area. Contact Jim Jackson 0532 524 721
November	28-29	South West Kit Car Show - Bristol Exhibition Centre. Definitely an indoor show but the Club has been offered a free stand. Anyone interested should contact M & A in the first instance.

Details Later  
Winter Dinner  
and Dance?

Date unknown,  
Place unknown,  
Price unknown!  
But Don Collins is working on venue etc. Watch this space.

1988

June	18-19	Newark
June	15-26	Meriden
August	13-14	Sandown
August	21	Fleetwood.

## EVENTS AND LOCAL MEETS

### FORTHCOMING EVENTS:

#### Kit Cars & Specials Day, Castlecombe September 19

These shows have been good throughout the year and there is no reason why Castlecombe should not follow suit. An Action Day really, with racing around the track for those interested. A fun day out! Look for the banner.

#### Club Trip to France 4-9 October

At the moment we have 21 cars taking part. The caravans have been booked for those who have expressed an interest, and camping for those with tents. B&B Portsmouth? Contact the Tourist Board tel:0705 826 722. A suggested itinerary for those interested is: Sun. Caen to La Fleche 120 mls; Mon. visit arranged to a wine Cave south of Saumur + Chinon area; Tues. visit Tours + area; Wed. invited to Chateau Loir + area; Thurs. Le Mans; Fri. return to Caen & ferry home. The area is beautiful and the scenery should be marvellous. DON'T FORGET YOUR MAPS and the suncream 'cos the weather is booked also. Any problems - contact Jim on 0532 524 721.

#### Winter Get Together

Don Collins is organising a winter Dinner/Dance/Disco on our behalf and although he hasn't yet any final details he has been working hard looking for the right venue. It will be as central as he can organise, probably in the Meriden area or thereabouts (handy for northerners or southerners), and he's arranging a nice meal, music, and overnight bed & breakfast. Further details when available.

### LOCAL MEETS:

Chadderton is still a very good meet. All Marlin enthusiasts of course, and quite a few new faces lately, but we'd like to see a few of the 'old' faces once more.

The Staines and Basingstoke meets are going strong. Particularly the Staines group. I think they must take over the pub - 30 loonies all together! Keep it up Kevin!

Andrew Berry has had to cancel the meet at the Churchillian, Cosham, through lack of support. Of course the inevitable will happen now, someone will contact us and ask for a meet in the Cosham area. Thanks Andrew for your efforts on our behalf.

The Preston venue (1st Tuesday at 8pm) is now at the UNICORN (not the Running Pump) on the A6, ½ mile from Preston town centre going north. Go along if you're in the area.

## EVENTS PAST

### Kit Cars & Specials Day, Knockhill 25 July

A very good event this with two Roadsters and two Berlinettas. The Yorkshire Kit Cars stand had a Berlinetta in which rides were available and very good it looked too!

Roy Firth

### RAF Woodvale 1-2 August

This was a very well organised and attended show. As usual there was a good turn out of Marlins, Roadster and Berlinettas. Congratulations are due to Nigel Ellis who won First Prize with his well trimmed Roadster. A very good effort with about 35 cars in the class. For those of you who haven't been to the Woodvale Show, I would recommend a visit. There are hundreds of very interesting veteran and vintage cars entered in the car classes and the model aircraft display was spectacular at times!

Doreen Hare

### Fleetwood 16 August

Despite scorching hot weather the turn-out was brilliant. Plenty of Marlins including the normal large contingent from the North East. Madam Chairman was in her element with full access to a radio-controlled microphone!! The day was very successful with the Club winning the long distance award - Graeme McAnelly; Best Open Sports - Peter Hare; and Best in Show - Terry Hambley. The Club Best of Show also went to Terry. Next year's date - Sunday 21 August.

### Sandown 8-9 August

The weather on Saturday threatened but didn't actually do anything. Sunday's forecast wasn't good so quite a few more than usual turned up on Saturday giving us 34 Marlins for the day with a good mixture of Roadsters & Berlinettas, including the one recently featured in the Daily Express.

A few stalwart members camped overnight -including a dog called Basil who was probably the most well behaved of the lot of us. We ignored the organised Bar B Q, although it did look to be very good value, but took full advantage of the bar and a superb jazz band. The Jago owners obviously enjoyed themselves but were very good about noise in the camping area.

Sunday saw reasonable weather with the rain, as at Newark, only catching people going home. I spent most of the day judging the main concours but Andrew, assisted by Sue Collins and Peter Hare did sterling work on the club stand retaining the Best Club Display Trophy won last year. The Club sponsored 3 entries in the concours and were rewarded by a 3rd in Class from Peter Hare. Peter just pipped Ben Caswell (by 2 votes) for our own Club Best of Show. Unfortunately Peter House's car was off the road and he was unable to repeat his clean sweep of 1986 in the driving skills. The day was celebrated with a birthday cake donated by Nina Davis - it was her birthday the day before and she thought we all ought to share the cake. Next year's date August 13-14.

Margaret

#### NEW KIT CAR CLUBS

Is anyone interested in joining a newly formed Kit Car Club, the LANCASHIRE KIT CAR CLUB? We have had details sent us of what sounds to be a very social gang and anyone interested can contact them on 0204 55601 (Brian Baggarley).

We are invited to join them at a TREASURE HUNT on 11 September at 7.00 p.m. - meeting at Bromley Cross Railway Station Car Park on the B6391 in Turton, Bolton. Details on the Club or the Pub Supper and Treasure Hunt can be obtained from Brian on the above number, or just turn up on 11 September. Sounds fun!?! Then go along.

Or then we have the WESSEX SPECIALIST KIT CAR CLUB who meet on the 2nd Tuesday of the month. This is for people in the Somerset, Taunton or Exeter, Wells areas. Their organiser is Norman Walker on 0278 662 131. Or you can always contact Marlin's Peter House on 0823 490 619 for details.

And another, the NORTH WEST KIT CAR CLUB newly opened with meetings on 2nd Sunday of each month at The Old Quay Tavern, Howley Lane, Warrington at 12 noon. Details from Dave on 0942 671 864, or Steve on 0244 380 358.

#### SECRETARY'S SCRIBBLINGS

Well we've done quite a lot this year haven't we? And we ain't finished yet, with Kit Shows still in the offing and the French Trip and a Winter Get Together being organised and Margaret already giving us dates for 1988.

As Margaret has mentioned there are quite a lot of members getting married this autumn - and using their Marlins on the wedding day. Congratulations to Sue Dale, Dick Crook, Alan Pollock and their 'intendeds' - we wish you all the very best.

Alan hasn't been having the best of luck lately - he blew his engine at Sandown, and "split his differentials" when he called to collect a new engine from Stockport. (Never mind Alan, a needle and thread will soon mend the jeans!)

I have been asked to point out to Mervyn Rogers that we're not giving a long distance award for the French Trip. Mervyn is coming back to England from his base in Cairo just to join us on holiday in France. How's that for enthusiasm! I bet he's on time and we're late (as usual). The least said about the Autotest at Sandown the better! Next year they're thinking of blindfolding the navigator and not the driver - mind you we all know that won't make much difference in my case, I'll still get lost!!

See you at the docks - we think.

Val

LOCAL MEETINGS1st Sunday (lunchtime)

Whitegates Inn, Broadway, Chadderton,  
Andrew Priest 0706 357 046

The Goat Inn, Hertford Heath,  
Charles Lancaster 0256 29830

Coach & Horses, Fieldhead, Marchfield  
off Jn 22 M1 - A50 to Leics  
Ken Dando 0530 39289

The Somerford Hotel, Christchurch  
(junction of A35 and A337).  
Keith Denham (Jago Owners Club) 0202 887 228

1st Monday (7.30 p.m.)

Rushpool Hall, Saltburn, Cleveland  
Tony Redcar 480480

1st Tuesday (7.30 p.m.)

Crooked Billet, on A30 in Staines  
Kevin Newton Deepcut 836545

The Unicorn, on A6, ½ mile from Preston  
Town Centre heading North  
Steve Purves Preston 715633

2nd Tuesday

Wessex Specialist Kit Car Club, Somerset,  
Taunton/ Exeter/ Wells area.  
Contact: Norman Walker 0278 662 131  
or Peter House 0823 490 619

1st Wednesday (8.00pm)

Tynemouth Motor Club HQ - North East Kit Car Club.  
Tony Cummings 091 438 1991  
Peter Cutts 0665 830 400

2nd Sunday (Lunchtime)

Kings Arms, Market Place, Melksham.  
Nick Marsh, The Cottage, Prestleigh,  
Shepton Mallet.

3rd Sunday (Lunchtime)

Buckles Inn, A64 nr. York  
Bryan Stanton York 58212

Ye Olde Bridge Inn, Oxton, A6097 East  
Dick Smith 0602 616930

Dorchester Arms, A30 between Hook and  
Basingstoke  
Kevin Newton Deepcut 83654

Last Tuesday (7.30 p.m.)

Old Barn Pub, Central Milton Keynes  
Brian Davis 0908 661094

Last Sunday (Lunchtime)

The Spread Eagle, off Junc.12 of M6, A5  
to Telford.  
Howard Dobson 0782 638405

## SALE BOARD

LWB Roadster for sale. 1300cc Marina, built 1984,  
13,000 miles, MOT, full weather gear, red. £2900 ono.  
Tel: G. Holding  
0202 743 273 (Poole)

WANTED Has anyone a Berlinetta for sale? We have had  
various calls asking for completed Berlinettas.  
Contact Val or Graham on 061 485 7444.

Marlin Logo for sticking to wheel covers/bodywork/  
dashboard etc. e.g. 2"x6" Marlin Logo on sticky back  
10 year Vinyl in Silver £1.25 each.  
Neil Cross, 155 Woodplumpton Rd., Fullwood, Preston  
Tel: 0772 729 497.

Marlin Owners Club Badges chrome on brass £11  
Ron Woollacott, 37 The Hollows, Wilford, Nottingham  
Tel: 0602 819454.

### For Sale from the Club:

Leather key fobs with logo	£1.00
Gear knobs with logo	£2.25
Round centres with logo	50p
1" lapel badges with logo	60p
Cloth M.O.C. badges	£1.75 or 3 for £5.00
Back issue of magazine	25p
Extra Windscreen stickers	25p.
Coasters @ 50p each or 6 for	£2.50

Contact: Margaret on 0706 357 046

WANTED My BERLINETTA is in desperate need of an  
OPEL badge! Does anyone have one they could sell me?  
Please contact P.Webb at 27 Carlbury Ave., Middlesbrough.

WANTED Has anyone any Marina front door locks and handles  
complete with keys? I'm willing to disassemble if  
necessary - Manchester/Cheshire area preferred.  
Contact Graham or Val 061 485 7444.

## TECH TIPS

### Door hinges

One point on the Berlinetta. Be sure to check your  
door hinges - the sizes can be slightly different.  
This could be very important especially when replacing  
them after spraying. Don't get them mixed!

Jim Davis

### Wiring

If you're having any problems with your wiring or  
difficulties on your electrics then contact Terry  
Chafer on 0904 28269 (York area). I can unhesitatingly  
recommend him for his workmanship and help.

Bob Walker

### Cooling

I've fitted the Austin 1800 (old type) radiator to my  
1950cc MGB lump, and the seems quite adequate in  
combination with a Kenlowe elec.fan and standard MGB  
oil cooler. I've chopped off the rad.filler cap and  
soldered on a small pipe going to an expansion bottle.  
This means the rad. can be mounted as high as possible  
in the cowling. Cost around £55.00 for a recond.unit.

Frank Taylor

A 3 core close tube radiator is available with header  
tank pipe to expansion bottle, for approx. £49. This  
is narrow enough to fit between the chassis rails and  
is therefore easier to fit. Available from H.A.Rayson,  
Tel: Taunton 275 044.

### 3L Essex Engine

We have a gentleman who has fitted a 3L Essex engine in  
his Berlinetta. Has anyone else? If so, which exhaust  
manifold have you used. Give me a ring please on  
061 485 7444

Graham

## TRIMMING TOPICS

At the recent Meriden meeting, Chris Rushforth and myself were persuaded (coerced?) into taking on the task of co-ordinating trimming and finishing information for the Berlinetta and Roaster. Chris and I will be in touch with each other to exchange information on materials, suppliers, diy techniques etc. with a view to making the info available to members. So, if you have an obliging supplier, special service or have discovered any interesting fixtures, fittings etc. please contact Chris or myself.

### Folding hood frame for the Roadster

Many of you will recall the article in June 1985 in which Jim Jackson revealed the secrets of his folding hood mechanism. Not having access to machining facilities, I was not able to use Jim's design but it sowed the seeds for a simplified version which can be made with basic hand tools.

In response to requests for details, the following notes and sketches may help to overcome the problem of what to do with the hood frame when the sun shines. (The masochists amongst you who scorn the use of a hood can skip the next bit!)

Note: The dimensions quoted are taken from my own hood but this may vary from car to car depending upon the exact location of the hood sockets on cockpit sides and whether your hood has stretched in use.

If you are replacing an existing Marlin hood frame it is essential to get the frames of the new mechanism in the same position in order to ensure the correct fit of the hood. To this end I suggest the use of a temporary wooden jig to establish the position of the existing frame. The simple system which I used is shown in Fig.1.

### Folding hood cont'd

The dimensions of the two frame members and the links are shown in Fig.2. Whilst it may be possible to bend the aluminium tube by hand, it is much quicker, easier and more accurate to hire a central heating pipe bender from a tool hire shop. I found that the dimensions of the links and the holes in the frames are fairly critical in getting the two frames to fold down flat.

Each of the main hinges is made from two stainless steel/nylon boat fittings which are normally used as canopy frame pivots on motor cruisers etc. My local boat shop tells me that they are manufactured by Winwood Products and are identified as end plug fittings, catalogue no. 8606. The white nylon stem may be too large to fit into your hood frame but it can be gently filed to a tight push fit. The lower half of the assembly should be filed to be a snug fit in the existing hood socket and can be retained with a stud, washer and nut. The two fittings are joined with a suitable chromed bolt and nyloc nut to ensure a rattle free assembly.

The position of the main frame member is controlled by a pair of retaining straps which can also be extended to secure the frame and hood in the folded position.

The position of the forward frame is governed by the dimensions of the links but some adjustment is possible by filing the end of the frame tube where it butts on to the main frame ( see Fig.4).

In the folded position, the frame just touches my spare wheel and the rolled up hood fits inside the frame. However, be warned that a light coloured vinyl hood should not be allowed to rest against the spare tyre as there is a risk that the vinyl will be permanently discoloured.

Peter Hare



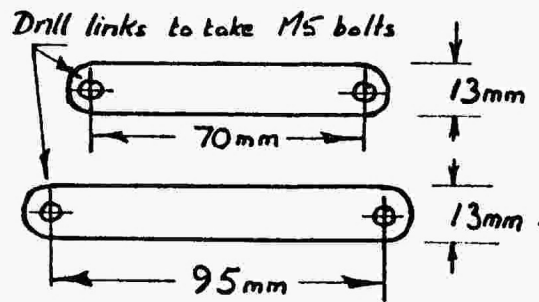
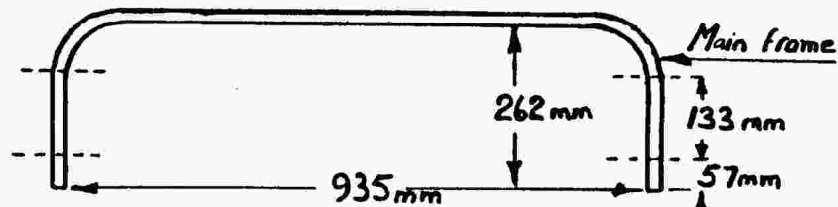
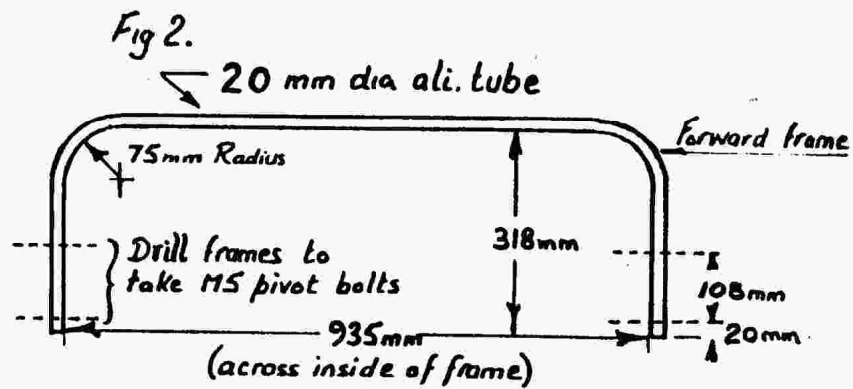
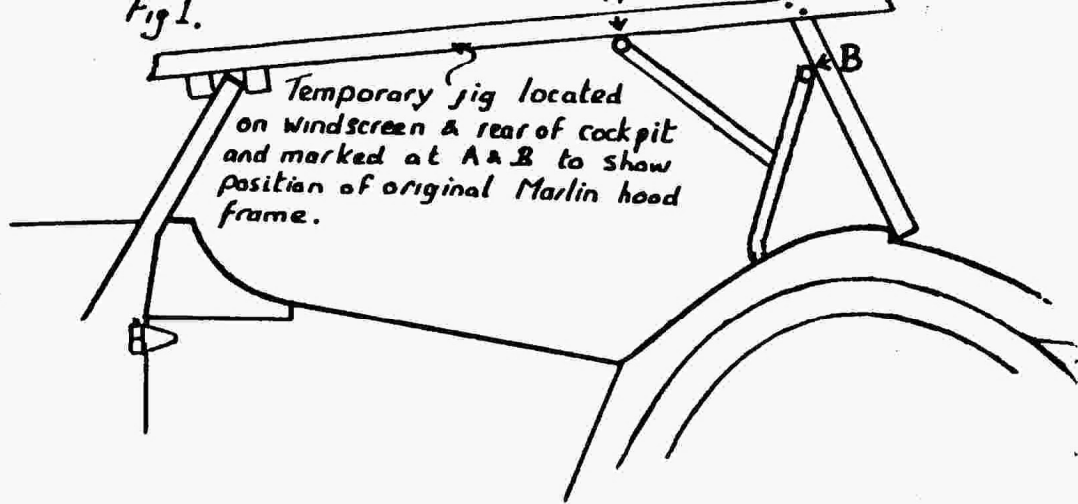

Links - 16swg ali - 4 off each

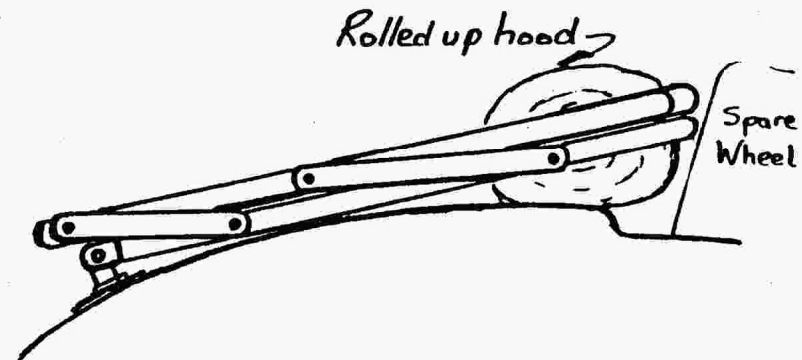
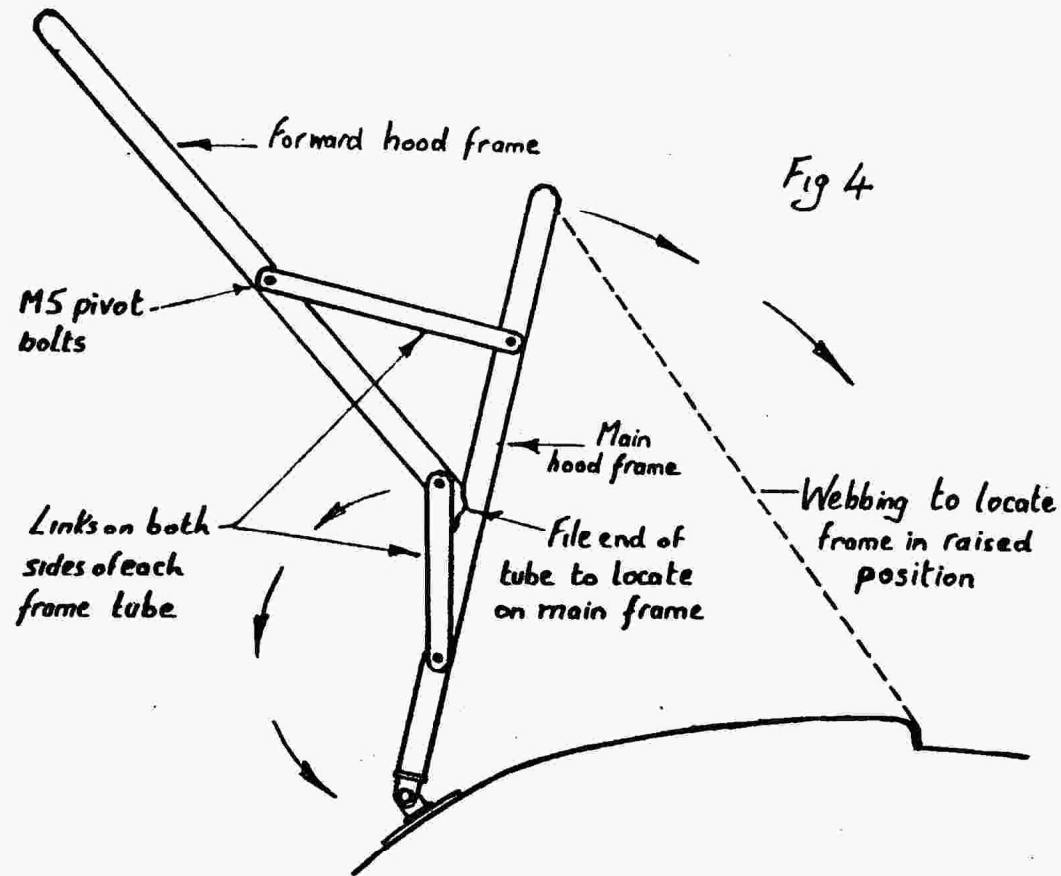
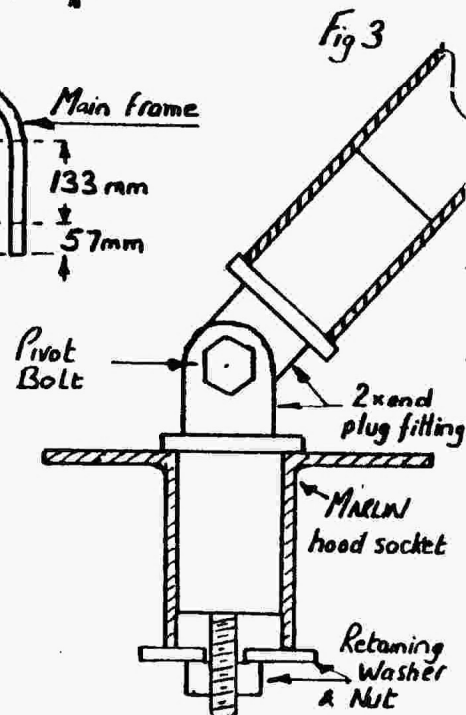

Registration? No Problem!

Build up complete but Registration had me worried. But it was easier than I thought. MOT 3.9.86 at 9.00 a.m., DVLC Office in Bristol in the Scamp at 10.15 a.m.  
"Have you got the vehicle with you sir?"

"No, I didn't think I could bring it!"

"Oh, yes. I will give you a note in case you get stopped."

11.15 a.m. with Marlin at DVLC. Documents handed in and quick walk around the vehicle to check the engine number and chassis number. Back in, receipts returned, road tax paid, tax disc and registration number issued. Left DVLC at 11.40 a.m. MOT to Registration in approx. 2.20 hours.

How's that!!!

11.50 a.m. stopped by the Police!

"No number plates sir?" Documents presented.

"Oh, I can't argue with that can I?"

What is it?

Did you build it?

How much did it cost?

How long did it take?

What's it based on?

Could anyone build one?"

I don't think they were really worried about the number plates, they just wanted to have a good look round.

Ken Bailey